

A-615DS

IN-CEILING SPEAKER



The A-615DS in-ceiling speaker combines the performance of the A-615 with the convenience of a dual-channel, or single-point stereo design.

The 6½-inch PolyGraphite woofer and dual ¾-inch swivel tweeters combine to provide high fidelity and stereo sound in a single slender, flush-trim design.



REDEFINING THE WAY YOU EXPERIENCE SOUND.™

382 Marshall Way, Layton, Utah • USA • 84041 • Toll Free: (800) 543-2205 • Fax: (801) 543-3300 • www.rbhsound.com
It is RBH Sound policy to continuously incorporate improvements into products; all specifications are subject to change without notice. Copyright © 2011 RBH Sound. All Rights Reserved.

SPECIFICATIONS

MODEL NAME:

A-615DS

SYSTEM TYPE:

In-ceiling 2-way Dual Channel Speaker

SERIES

Architectural Series

FREQUENCY RESPONSE

55Hz — 20kHz \pm 3dB

SENSITIVITY

90dB (2.83 Volts @ 1 Meter)

RECOMMENDED POWER

10-80 Watts

DRIVE UNITS

- (1) 6½" (165mm) PolyGraphite Cone Woofer
- (2) ¾" (19mm) Swivel Silk Dome Tweeters

TWEETER PROTECTION

Yes

CROSSOVER FREQUENCY

3,000 Hz

CROSSOVER

12dB/Octave

IMPEDANCE

8 Ohms x 2

CABINET

White Frame (paintable)

GRILLE

White (paintable)

CUTOUT DIMENSIONS

7-3/4" (197mm) Diameter

FINSIHED DIMENSIONS

9-1/8" Diameter x 4" D
(232mm Diameter x 102mm D)

WEIGHT

3.35 lbs. (1.52 kg)

WARRANTY

25 Years*



R B HASSING

™

High Performance Home Audio
Redefining the Way You Experience Sound™

A-615DS

IN-CEILING SPEAKER

DIMENSIONS

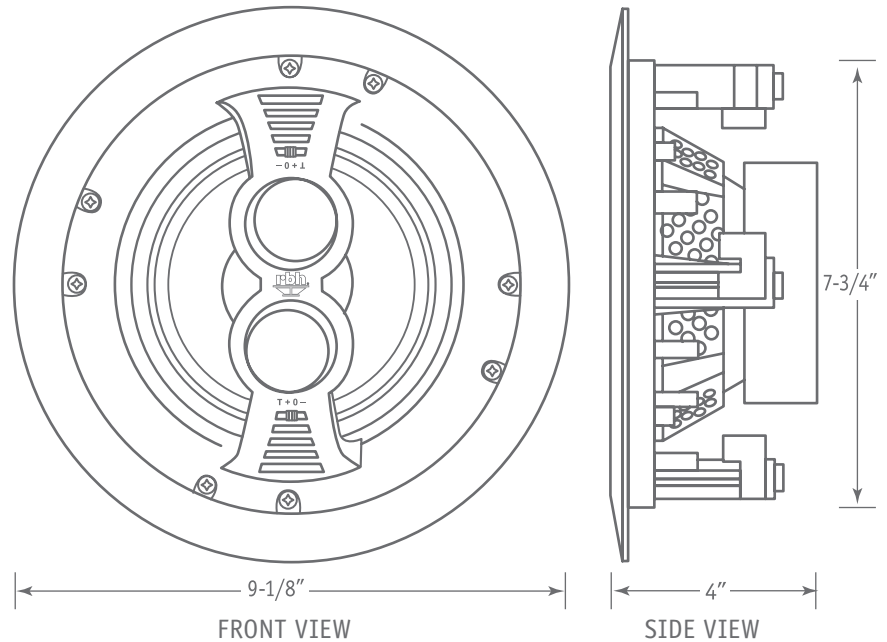

ACCESSORIES

The below accessories are sold separately.

BLANK PLATE: BP-6R

NEW CONSTRUCTION BRACKET: NCB-8R

*Warranted for 25 (twenty-five) years from date of purchase to be free from defects and workmanship. For more information see your RBH dealer.

Specifications are subject to change. For the most current information visit us online at www.rbhsound.com.