



# **MC-6AW / A-5AW**

## **Two-way Indoor/Outdoor Speakers**

*Installation and Operation Manual*

# Introduction

Congratulations on your purchase of RBH Sound MC-6AW or A-5AW indoor/outdoor speakers! These speakers are the result of many years of research and development dedicated to producing high quality products for home audio and audio/video systems.

This manual contains features, setup recommendations and specifications for the RBH Sound MC-6AW and A-5AW indoor/outdoor speakers. It is recommended you thoroughly read through the material contained in this manual before connecting your speakers. This will ensure you have a good understanding of how to setup your speakers for optimum performance and allow for years of listening enjoyment.

# Parts Guide

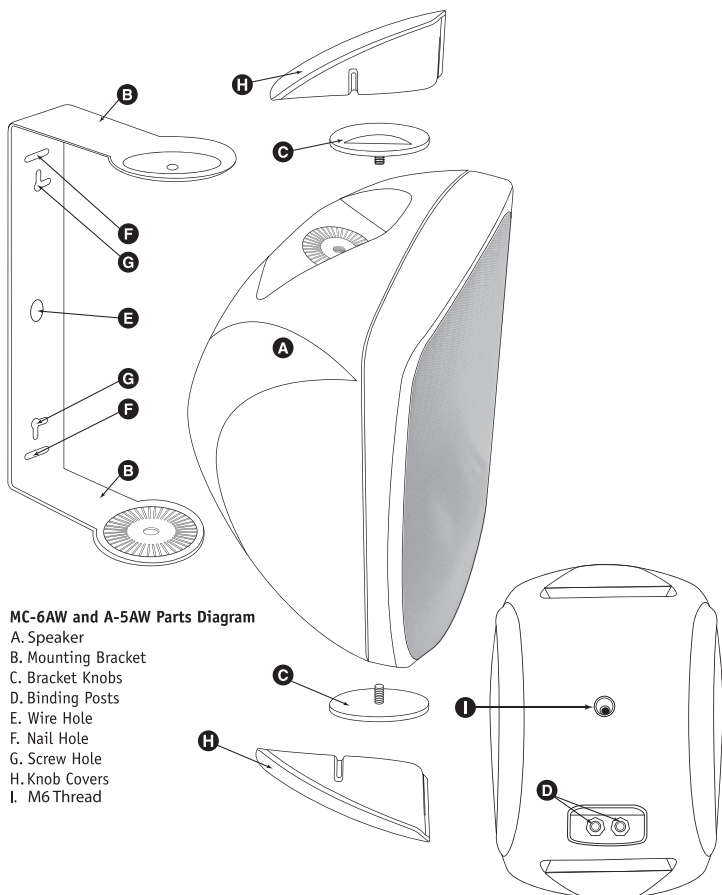

## Features

The cabinet of the MC-6AW and A-5AW is constructed of dense acoustically inert impact resistant polypropylene resin, sealed to provide protection from the natural elements of the weather. The rounded back allows for easy placement into a corner. All hardware parts are made from brass, aluminum or stainless steel and the binding posts are plastic to avoid rusting or corrosion.

For high frequencies, the MC-6AW uses a 1-inch high performance aluminum dome tweeter and the A-5AW features a high quality mylar dome tweeter. Both tweeters use liquid cooling to allow greater power handling. For midrange and bass reproduction the MC-6AW uses a 6½-inch high-end Aluminum cone woofer while the A-5AW uses a 5¼-inch PolyGraphite cone woofer.

Steep acoustic slope crossover networks are used to integrate the drivers, allowing high power handling, minimizing driver interaction anomalies, and maximizing the clarity with which each driver is able to produce its respective frequency band.

## Break-in Period

Allow several hours of listening time to adequately break-in the speakers. As the speakers break-in, the driver suspensions will loosen. The result of break-in will be an increase in low frequency response, improved definition, and increased clarity and detail.

**NOTE:** This is an important step that is often disregarded. Allowing your speakers the specified break-in period can prolong the life of your speakers and enhance their tonal qualities.

## Speaker Placement

Establish where the most likely or average listening area will be. Ideally, speakers should be placed on either side of the targeted listening area with at least 8 to 10-feet of total separation. For best performance, try to leave at least 4 to 5-feet of distance between each speaker and the listening area. The distance from the listening area to each speaker should be close to the distance that separates the two main speakers. Angling the speakers inward towards the listening position may give a more spacious and realistic sound stage. Experiment with speaker placement to determine which location offers the best overall sound.

Placing the speakers in a corner or under an eave will provide reinforcement for the bass frequencies, resulting in higher bass output. Placing the speakers away from any corners or walls will provide the least amount of reinforcement, resulting in lower bass output.

## Speaker Placement

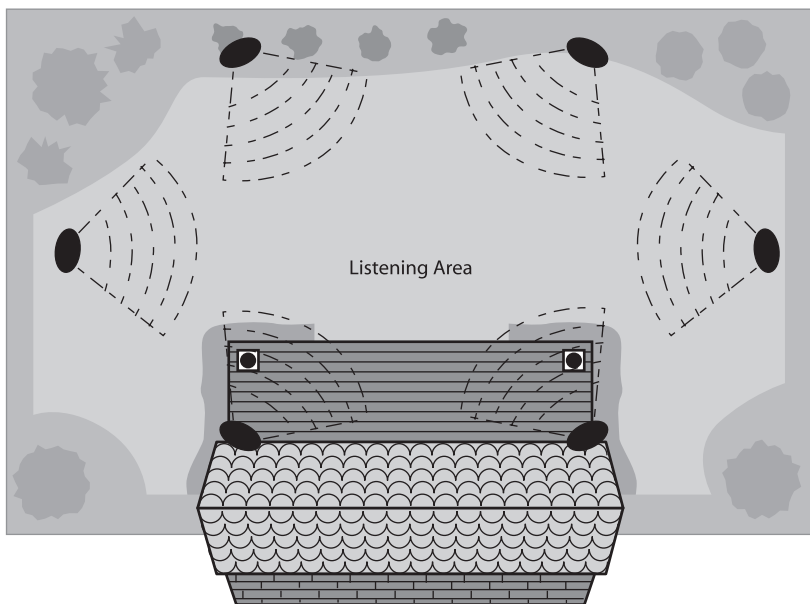

## Installation

The bracket has the ability to be mounted a variety of different ways. It may be mounted with either nails or screws, horizontally or vertically. There is a hole in the center of the bracket to allow speaker wire through so it may be properly attached to the speaker. The cabinet back has a female M6x1.0mm thread for an optional swivel bracket mount.

If working properly, insert the knob covers to complete the installation.

### Mounting and Connections

For the following instructions you may need to refer to the Parts Guide section located on the first page of this manual.

1. The speaker may be mounted either horizontally or vertically. Hold the bracket against the mounting surface, so you can mark the locations of the mounting holes, and the wire hole.
2. Drill corresponding pilot holes for the mounting screws or nails and a hole large enough for the speaker wire to pass through.
3. Pull the speaker wire through the hole and through the bracket, aligning the bracket with the pilot holes.
4. Use hardware to attach the bracket to the mounting surface.

## Installation (continued)

5. Use the bracket knobs to attach the speaker to the bracket, being careful to not tighten the knobs until the desired location is attained; this will allow the speaker to be angled slightly so the rear binding posts are accessible.
6. Connect one wire to the black terminal and one to the red terminal, paying close attention to the markings on the wire for proper polarity. Each speaker must be connected to the amplifier in the same way.

**NOTE:** Before proceeding, if you are unfamiliar with running speaker wires and are uncomfortable with this type of installation, please contact a qualified installation professional.

When all connections have been made and double-checked, turn on your receiver/amplifier and test for proper operation by walking around the listening area to ensure sound is coming from all connected speakers. If a speaker is not working correctly, please refer to the troubleshooting section of this manual. If working properly insert knob covers to complete installation.

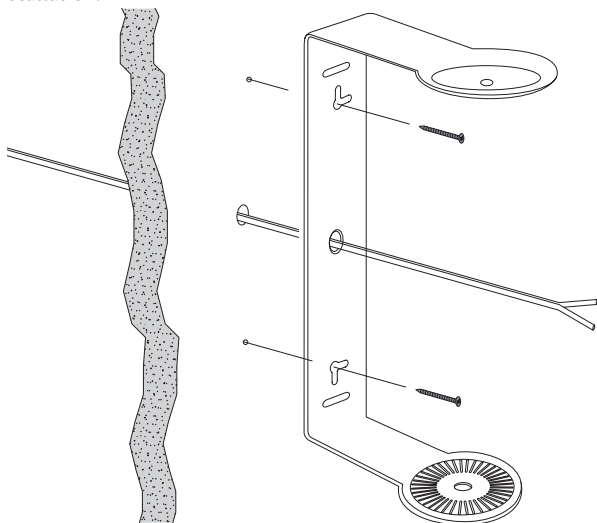

## Operation

An amplifier with an output power rating of 25-100 watts per channel is recommended. This will help to protect the speaker from being under or over driven, which may cause permanent damage.

When listening to the speakers outdoors, keep in mind that there are very few walls to reinforce the sound. Therefore, be careful not to drive the speakers beyond their capabilities when trying to obtain a desired volume level. You will be able to determine audibly when the speaker is being overdriven by the "break up" or distorted sound that will be coming from the speaker.

# Troubleshooting

Situation:	Probable Cause:	Solution:
No sound from speakers.	<p>Speaker wire not connected.</p> <p>Speaker selector on amplifier is not on.</p>	<p>Make sure wire is connected at both the speaker and the amplifier observing proper polarity.</p> <p>Activate proper selector on amplifier.</p>
No sound from one speaker.	<p>Balance control on receiver or pre-amp is not centered.</p> <p>Speaker wire not securely connected.</p>	<p>Place balance control in the center.</p> <p>Check all connections at amplifier and speakers.</p>
Very little bass and/or imaging	Speakers are wired out of phase.	Check entire system for proper polarity and make adjustments as necessary

# Specifications

Model:	MC-6AW	A-5AW
<b>Woofers:</b>	6½-inch (165mm) Aluminum Cone	5¼-inch (133mm) PolyGraphite Cone
<b>Tweeters:</b>	1" (25mm) Aluminum Dome	1" (25mm) Mylar Dome
<b>Recommended Power:</b>	10-130 Watts	10-85 Watts
<b>Impedance:</b>	8 Ohms	8 Ohms
<b>Frequency Response:</b>	54Hz-20kHz ±3dB	59Hz-20kHz ±3dB
<b>Sensitivity:</b>	89dB	88dB
<b>Crossover Slope:</b>	12dB/Octave	12dB/Octave
<b>Dimensions (Including Bracket):</b>	<p>Width: 9" (228mm)</p> <p>Height: 12¾" (324mm)</p> <p>Depth: 8¼" (210mm)</p>	<p>Width: 7½" (190mm)</p> <p>Height: 11" (279mm)</p> <p>Depth: 7¼" (184mm)</p>
<b>Cabinet:</b>	Black Cast Poly-Resin	Black Cast Poly-Resin
<b>Grille:</b>	Black Aluminum Micro-perf	Black Aluminum Micro-perf
<b>Weight:</b>	9.1 lbs. (4.13 Kg) Each	5.9lbs. (2.68 Kg) Each

## Warranty

Your RBH Sound MC-6AW or A-5AW indoor/outdoor speaker is covered by a limited warranty against defects in materials and workmanship for a period of 5 (five) years from the original date of purchase. This warranty is provided by the authorized RBH Sound dealer where the speakers were purchased. Warranty repair will be performed only when your purchase receipt is presented as proof of ownership and date of purchase. Defective parts will be repaired or replaced without charge by your dealer's store or the location designated by your dealer authorized to service RBH Sound products. Charges for unauthorized service and transportation cost are not reimbursable under this warranty. This warranty becomes void if the product has been damaged by alteration, misuse or neglect. RBH Sound assumes no liability for property damage or any other incidental or consequential damage whatsoever which may result from the failure of this product. Any and all warranties of merchantability and fitness implied by law are limited to the duration of this express warranty. Some states do not allow limitations on how long an implied warranty lasts, so the above limitations may not apply to you. Some states do not allow the exclusion or limitation of incidental or consequential damages, so the above limitation or exclusion may not apply to you.

*Redefining The Way You Experience Sound.<sup>TM</sup>*



382 Marshall Way, Layton, Utah • USA • 84041  
Toll Free: (800) 543-2205 • Fax: (801) 543-3300  
[www.rbhsound.com](http://www.rbhsound.com)

It is RBH Sound policy to continuously incorporate improvements into products; all specifications are subject to change without notice. Copyright © 2008-2009 RBH Sound. All Rights Reserved.